



**Gas monitoring system for fast and reliable detection of flammable and toxic gases used in industrial manufacturing processes**

# Midas®



## Features:

- Over 40 gases available with extended 2 year warranty\*
- Smart sensor cartridge with on board 'e-calibration' certificate
- 3 built in relays (Form C) for Alarm 1, 2 and Fault
- Power over Ethernet (PoE) communication and power platform
- Keypad Interface and remote Web Browser Interface
- Pyrolyzer and LonWorks® interface optional modules that connect to any transmitter
- Password protected menu levels to preserve system integrity
- Bright LEDs and intuitive Icon Driven, large backlit LCD display
- Factory-calibrated sensors to reduce need for frequent gas testing
- Isolated 0-22 mA Analog Output with fault and event reporting
- Modbus/TCP Ethernet for easy connectivity to all control and alarm systems ports for control connectivity and service interaction
- Robust extractive pump system (2 year lifetime) sampling up to 30m
- Interactive Training Simulator tool
- CE marked for total immunity to Radio Frequency Interference
- Reflex® sensor health check for improved safety
- TempraSure™ temperature compensation technology as appropriate
- Event logging to review sensor history
- Patented reporting technology confirms likely gas release to avoid nuisance alarms

(\* standard 1 year warranty)

**Midas® is a gas monitoring system for fast and reliable response to the presence of virtually all of the gases used or generated in the Semiconductor and other industrial manufacturing applications. Midas® offers lower cost of ownership benefits for gas detection through a combination of extended sensor calibration periods, flexible communications architecture and patented diagnostics that monitor sensor performance and flow control.**

Midas® is a universal transmitter platform that detects the majority of toxic, ambient and flammable gases that must be monitored in a typical industrial process environment. The pre-calibrated 'plug-and-play' smart sensor cartridge makes sensor replacement quick and easy to manage with no tools required, and prevents any operator error associated with using incorrect or depleted sensors. Bright LED lights and an intuitive, icon driven interactive menu guarantee instant alert to the gas reading or alarm level coupled with password protected menus for configuration, test and calibration.

Midas® is very compact in size and its easy access metal chassis design makes it simple to install in crowded, increasingly complex process environments or retro fit applications where space is at a premium. Midas® has flexible power and communications built in as standard including 3 on-board relays, 0 - 22mA analog output, Modbus/ TCP Ethernet digital outputs, as well as the innovative Power over Ethernet (PoE) protocol - a single Ethernet connection for all power, control and communication requirements. Cost effective integration with PLC and FieldBus systems is greatly simplified with the Midas® architecture.

Midas® will monitor points up to 30m (100 feet) away from the transmitter and flow rates are regulated automatically using patented control technology to ensure error free gas sensing operation. Honeywell Analytics designs and manufactures its own sensors using advanced robotics to ensure unbeatable quality and reliability.

Midas® is complimented by the innovative Chemcassette® range of ultra sensitive low ppb toxic gas detection analyzers and our worldwide network of service engineers who operate on a 24/7 basis.



# Installation Details



## Mechanical

### Removing cover

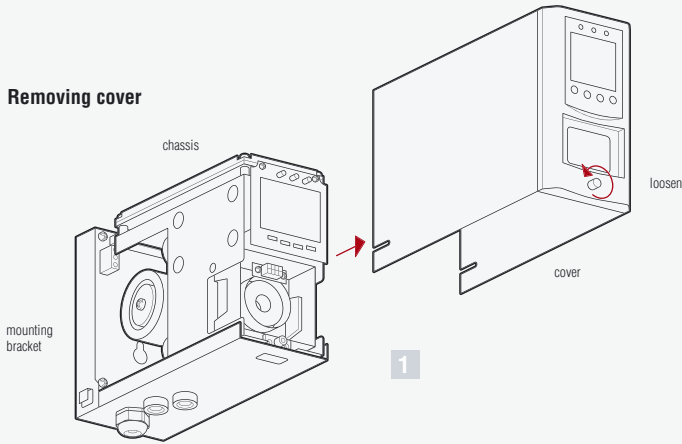

### Refitting chassis aligning connector and tubing

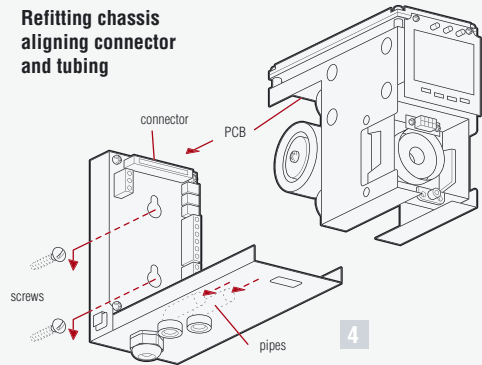

### Removing chassis

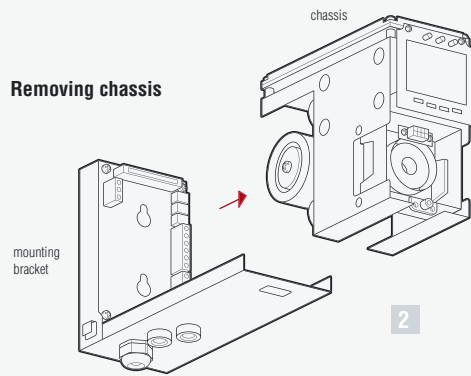

### How cartridge is fitted

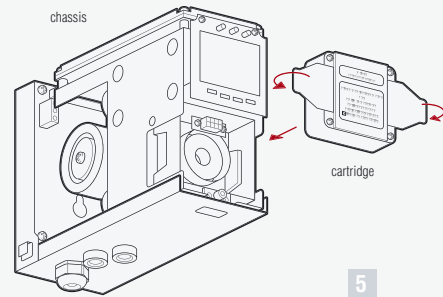

### Attaching bracket to screws on a wall

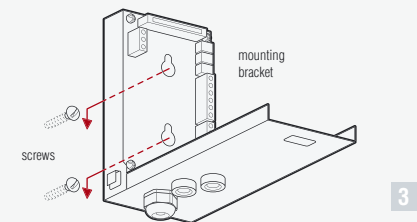

### How cover is fitted

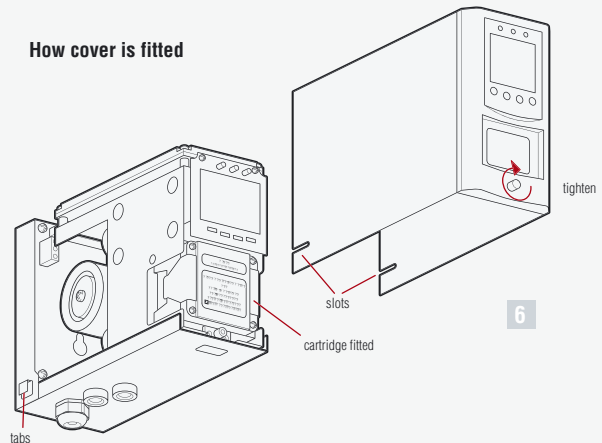



# General Specifications



## Electrical

All wiring permutations shown for example purposes

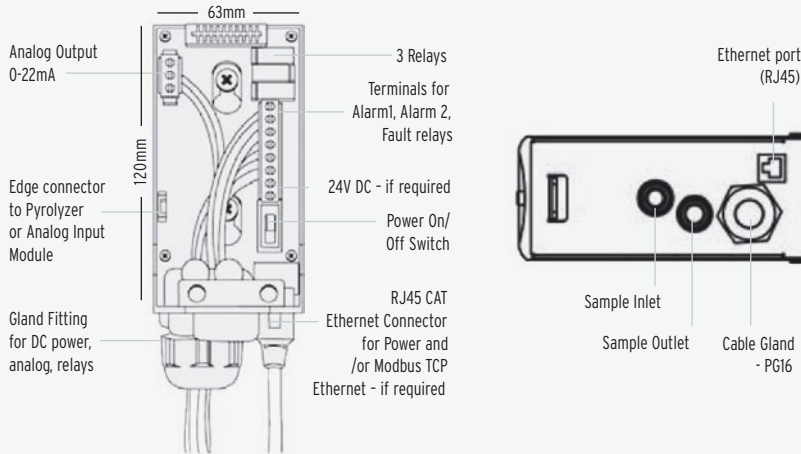

## Detectable Gases

Gas Name	Chemical Formula	Range	Sensor Part Number
Ammonia	NH <sub>3</sub>	0 - 100 ppm	MIDAS-S-NH3
Arsine	AsH <sub>3</sub>	0 - 0.2 ppm	MIDAS-S-ASH
Boron Trichloride	BCl <sub>3</sub>	0 - 8.0 ppm	MIDAS-S-HCL
Boron Trifluoride	BF <sub>3</sub>	0 - 8.0 ppm	MIDAS-S-HFX
Boron Trifluoride (Low Level)	BF <sub>3</sub>	0 - 2.0 ppm	MIDAS-S-HFL
Bromine	Br <sub>2</sub>	0 - 0.4 ppm	MIDAS-S-BR2
Carbon Dioxide	CO <sub>2</sub>	0 - 2.0 % vol	MIDAS-S-CO2
Carbon Monoxide	CO	0 - 100 ppm	MIDAS-S-COX
Chlorine	Cl <sub>2</sub>	0 - 2.0 ppm	MIDAS-S-HAL
Chlorine Dioxide	ClO <sub>2</sub>	0 - 0.4 ppm	MIDAS-S-BR2
Chlorine Trifluoride	ClF <sub>3</sub>	0 - 0.4 ppm	MIDAS-S-SF4
Diborane	B <sub>2</sub> H <sub>6</sub>	0 - 0.4 ppm	MIDAS-S-HYD
Dichlorosilane	H <sub>2</sub> SiCl <sub>2</sub>	0 - 8.0 ppm	MIDAS-S-HCL
Difluoromethane	CH <sub>2</sub> F <sub>2</sub>	0 - 120 ppm	MIDAS-S-CFX
Disilane	Si <sub>2</sub> H <sub>6</sub>	0 - 20 ppm	MIDAS-S-SHX
Fluorine	F <sub>2</sub>	0 - 4.0 ppm	MIDAS-S-HAL
Germane	GeH <sub>4</sub>	0 - 0.8 ppm	MIDAS-S-HYD
Hexafluorobutadiene	C <sub>4</sub> F <sub>6</sub>	0 - 40 ppm	MIDAS-S-CFX
Hydrogen (% LEL)*	H <sub>2</sub>	0 - 100% LEL	MIDAS-S-LEL
Hydrogen (ppm)	H <sub>2</sub>	0 - 1000 ppm	MIDAS-S-H2X
Hydrogen Bromide	HBr	0 - 8.0 ppm	MIDAS-S-HCL
Hydrogen Chloride	HCl	0 - 8.0 ppm	MIDAS-S-HCL
Hydrogen Cyanide	HCN	0 - 20 ppm	MIDAS-S-HCN
Hydrogen Fluoride	HF	0 - 12 ppm	MIDAS-S-HFX
Hydrogen Fluoride (Low Level)	HF	0 - 2.0 ppm	MIDAS-S-HFL
Hydrogen Selenide	H <sub>2</sub> Se	0 - 0.4 ppm	MIDAS-S-HSE
Hydrogen Sulfide	H <sub>2</sub> S	0 - 40 ppm	MIDAS-S-H2S
Hydrogen Sulfide (High Level)	H <sub>2</sub> S	0 - 100ppm	MIDAS-S-HSH
Methane (% LEL)*	CH <sub>4</sub>	0 - 100% LEL	MIDAS-S-LEL
Methyl Fluoride	CH <sub>3</sub> F	0 - 60 ppm	MIDAS-S-CFX
Nitrogen Dioxide	NO <sub>2</sub>	0 - 12 ppm	MIDAS-S-NO2
Nitrogen Oxide	NO	0 - 100 ppm	MIDAS-S-NOX
Nitrogen Trifluoride	NF <sub>3</sub>	0 - 40 ppm	MIDAS-S-HFX
Octofluorocyclopentene	C <sub>5</sub> F <sub>8</sub>	0 - 40 ppm	MIDAS-S-CFX
Oxygen Proficiency & Deficiency	O <sub>2</sub>	0 - 25% vol	MIDAS-S-O2X
Ozone	O <sub>3</sub>	0 - 0.4 ppm	MIDAS-S-O3X
Phosphine	PH <sub>3</sub>	0 - 1.2 ppm	MIDAS-S-PH3
Phosphorous Oxychloride	POCl <sub>3</sub>	0 - 0.4 ppm	MIDAS-S-POC
Silane	SiH <sub>4</sub>	0 - 20 ppm	MIDAS-S-SHX
Silane (low level)	SiH <sub>4</sub>	0 - 2.0 ppm	MIDAS-S-SHL
Sulfur Dioxide	SO <sub>2</sub>	0 - 8.0 ppm	MIDAS-S-SO2
Sulfur Hexafluoride	SF <sub>6</sub>	0 - 8000 ppm	MIDAS-S-CFX
Sulfur Tetrafluoride	SF <sub>4</sub>	0 - 0.4 ppm	MIDAS-S-SF4
Tetra Ethyl Ortho Silicate	TEOS	0 - 40 ppm	MIDAS-S-TEO
Tungsten Hexafluoride	WF <sub>6</sub>	0 - 12 ppm	MIDAS-S-HFX
Tungsten Hexafluoride (Low Level)	WF <sub>6</sub>	0 - 2.0 ppm	MIDAS-S-HFL

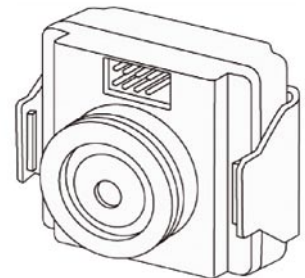

For standard 1 year sensor warranty use the order part number format MIDAS-S-XXX; for extended 2 year warranty use the format MIDAS-E-XXX

\* Midas® detectors are not ETL approved for monitoring in or sampling from classified areas above 25% LEL

# Technical Summary



Transmitter Dimension	
Size (unit with Sensor)	120mm (H) x 63mm (W) x 150mm (D)
Weight (unit with Sensor)	0.8kg
Pyrolyzer Dimensions (Regular and High Temperature versions)	
Size (MIDAS-T-00P)	70mm (H) x 63mm (W) x 83mm (D)
Weight (MIDAS-T-00P)	0.41Kg
Size (MIDAS-T-HTP)	113mm (H) x 101mm (W) x 140mm (D)
Weight (MIDAS-T-HTP)	1.25Kg
Power Requirements	
Operating Voltage	24V DC Nominal +/- 10%
Operating Voltage with Power over Ethernet (PoE)	36 - 57 VDC via PoE, 48V DC Nominal
Power Consumption	
Transmitter Unit	~ 5.0 W
With Pyrolyzer (Option)	< 12.95 W
Outputs	
Visual	Alarm, Power and Fault lights as well as back lit LCD display with all gas readings and events
Relays	3 relays for Alarm1, Alarm 2 and Fault rated 1.0A @ 30VDC or 0.5A @125VAC; configurable NO or NC, latched or unlatched
Analog	2 wire isolated, 0 - 22mA, Sink or Source
Digital Communications	Standard: Modbus / TCP Ethernet / Power over Ethernet (PoE). Option: LonWorks®
Service Port	RS232C / PPP protocol
Certification & Specification	
European	CE marked; meets EN 50270:1999 (Type2) and EN 55011:2000
Environmental	ETL approved UL 61010B and CSA-C22.2 No. 1010.1-92
Performance	Designed to meet with UL 2075 (pending 2004)
Electrical	IEEE 802.3af-2003
Response Times	
Flow Rate	500 mL/min
Transport Time	2 - 30 seconds maximum
Performance	
	LDL < LAL
	LAL = ½TLV (typically 12% FSD)
	FSD = 4 x TLV

Sampling Distance	
Tubing Length	Up to 30m (100 feet) with FEP tubing dependant on gas
Ambient Point Monitoring	In line air filter recommended
Exhaust Length	Up to 30m (100 feet)
Tubing Requirement	
Sample	6.35mm OD (1/4") x 3.18mm (1/8"), FEP, 30m (100 feet) maximum dependant on gas type
Exhaust	6.35mm (1/4") OD x 4.76mm (3/16"), FEP, 30m (100 feet)
Operating Temperature	
Unit with Sensor	0°C (32°F) to 40°C (104°F)
Wiring Requirement	
4-20mA/DC Power/Relays	14 AWG Maximum
Digital	Shielded CAT 5 cable or equivalent, RJ45 connector
Gas Concentration Display & Interface	
Instrument	4-digit alphanumeric display with separate measurement units, flow rate bar graph and other icon driven indicators. 4 button membrane keypad
Remote Interface	PC / PDA Internet Browser access via Ethernet or other Bus system
Warranty	
Transmitter Unit	1 year
Sensor Cartridge	1 year standard; 2 year with extended warranty program
Expected Lifetime of Pump	> 2 years
Installation Details	
Mounting	Wall mounted using 2 pre-drilled holes on rear chassis
Material	Steel case with paint finish

Ordering Information	
UNIT	PART NUMBER
Transmitter	MIDAS-T-001
Pyrolyzer (NF <sub>3</sub> )	MIDAS-T-00P
Pyrolyzer (High Temperature)	MIDAS-T-HTP
LonWorks® Interface	MIDAS-T-LON

MDA Scientific has developed a sophisticated range of highly sensitive gas detection equipment, designed to perform in ways that define new gas detection performance levels providing total solutions to protect people, improve production efficiency and reduce costs.

## The MDA Scientific range of toxic gas detection



**Single Point Monitor**

The SPM overcomes the difficulty of ensuring that basic units for toxic gas monitoring are accurate and free of interference from environmental conditions or other chemicals, by using our interference-free Chemcassette® detection technique. The SPM can also be used outdoors and has heating and cooling options to suit environmental conditions.



**Vertex**

Vertex provides a flexible, cost-effective monitoring solution that can adapt to changing needs. Using advanced Chemcassette® software and optics technologies, Vertex can monitor from 8 to 72 points of gas detection, up to 9 gas families and more than 40 gases.



**Model IR-148**

The Model IR-148 detects solvents and gases such as HCFCs, HFCs and PFCs that are otherwise difficult to monitor without the effect of cross-interfering gases.



**Midas®**

Midas® can measure virtually all the toxic and flammable gases found in manufacturing and storage applications. The range is in fact a universal transmitter design that differs significantly from the Lifeline II range which had separate passive, extractive and pyrolyzer variants with different footprints and performance characteristics.



**CM4**

CM4 provides monitoring of toxic gases at four locations, up to 300 feet away – detection of ppb levels of toxic gases at multiple points. Points are monitored continuously. Leaks are detected within seconds.

### Find out more

[www.honeywellanalytics.com](http://www.honeywellanalytics.com)

### Customer business centre

#### Europe and the rest of the world

Honeywell Analytics AG  
 Wilstrasse 11-U11  
 CH-8610 Uster  
 Switzerland  
 Tel: +41 (0)44 943 4300  
 Fax: +41 (0)44 943 4398  
[sales@zelana.co.uk](mailto:sales@zelana.co.uk)

### Customer business center

#### Americas

Honeywell Analytics Distribution, Inc.  
 400 Sawgrass Corporate Pkwy  
 Suite 100  
 Sunrise, FL 33325  
 USA  
 Tel: +1 954 514 2700  
 Toll free: +1 800 538 0363  
 Fax: +1 954 514 2784  
[sales@zelana.com](mailto:sales@zelana.com)

[www.honeywell.com](http://www.honeywell.com)



**IN-USA**

The IN-USA range of microprocessor controlled analyzers detect trace amounts of ozone (O<sub>3</sub>) gas. Systems can be configured with relays and different signal output options for integration within life safety networks. High levels of signal sensitivity and resistance to false alarm are enabled by the use of advanced ultraviolet (UV) lamp detection systems.



**Chemcassette®**

The Chemcassette® detection system is the heart of an MDA toxic gas monitoring system. Chemcassettes® use a dry reagent medium to collect and analyze air to detect gas leaks. When the Chemcassette® is exposed to a target gas, it changes color in direct proportion to the concentration of gas present. MDA Scientific monitors read color intensity changes and determine the gas concentration by comparison to a known gas response pre-programmed into the instrument.

#### Please Note:

While every effort has been made to ensure accuracy in this publication, no responsibility can be accepted for errors or omissions. Data may change, as well as legislation, and you are strongly advised to obtain copies of the most recently issued regulations, standards, and guidelines. This publication is not intended to form the basis of a contract.  
 © 2005 Honeywell Analytics

H\_Midas\_DS\_V1  
 12/05

© 2005 Honeywell Analytics

# Honeywell